

RADIAL FANS

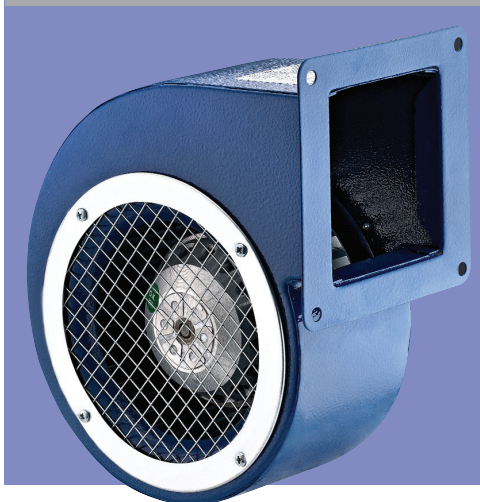

BDRS

AC CENTRIFUGAL BLOWERS Sheet Metal Body

BDRS Single Inlet blower's compact structure benefits space saving for various cooling and ventilation applications.

Technical Drawings

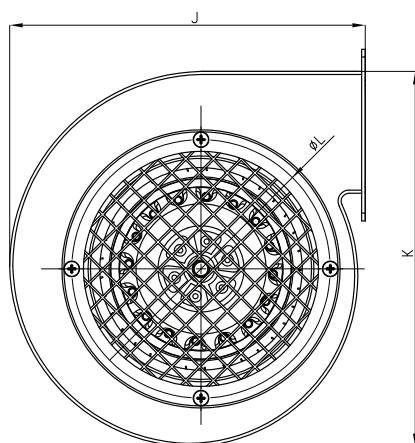
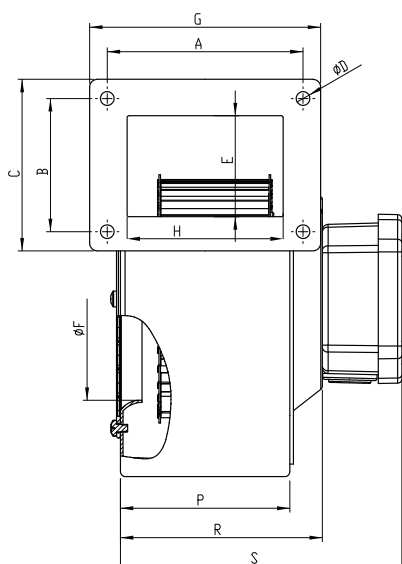

MATERIAL

: Housing is electrostatic powder coated sheet steel. Impeller is forward curved, galvanized.

INSULATION CLASS

: Class B

DIRECTIVE

: EN 60335-1, EN 60335-2-80

SPEED CONTROL

: Speed can be adjusted using an optional controller.
(BSC-1 / BSC-2)

APPLICATION AREAS

: The BDRS centrifugal fan series are perfect to use in industrial and commercial environments, mainly for local cooling applications, blowing in heating systems. Machines cooling, boilers, yacht air conditioning, dc motor cooling, plastic machines, sock machines, electric board cooling, laboratories, residential and industrial areas etc.

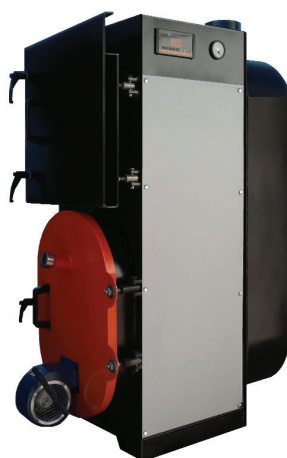

Accessories



BSC

TYPE	A	B	C	D	E	F	G	H	J	K	L	P	R	S
BDRS 125-50	72	77	88	5	62	98	86	66	170	180	128	66	68	94
BDRS 120-60	98.5	69.5	100	6	67.5	97.5	115.5	81	173	183	133	83	93	134
BDRS 140-60	112	112	129.3	6.5	91.5	112	129	83.5	206	216	151	86	92	133
BDRS 160-60	112	112	129.3	6.5	92.5	130	129	84	270	260	165	94	100	141

Dimensions are in (mm)

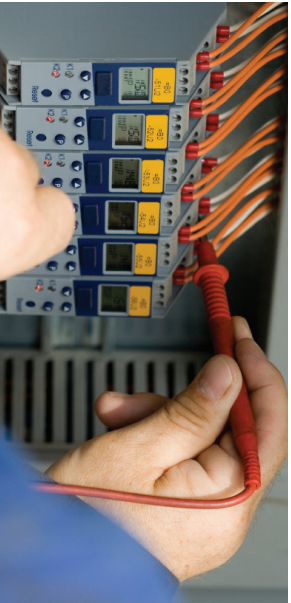
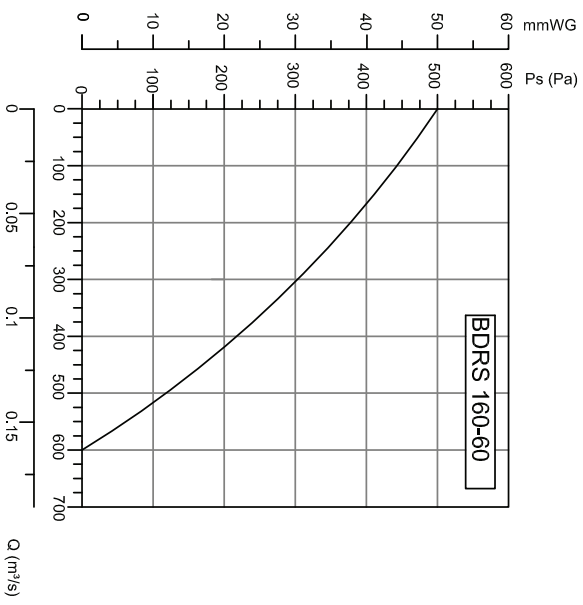
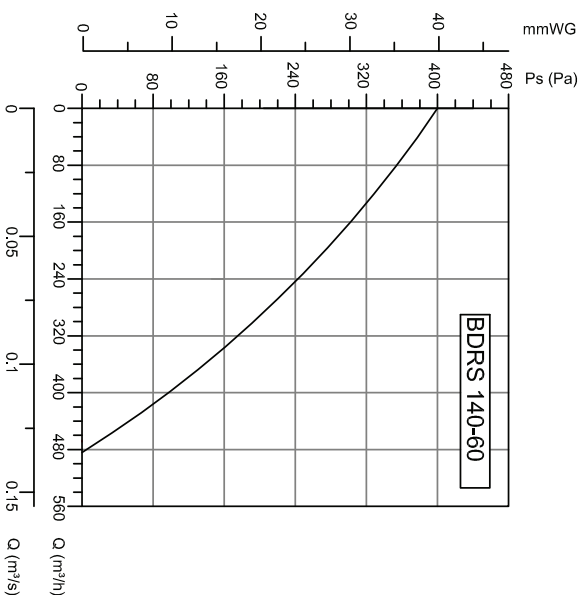
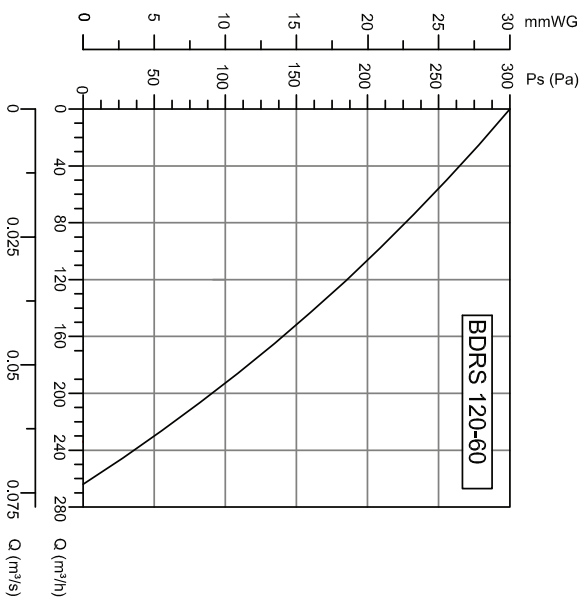
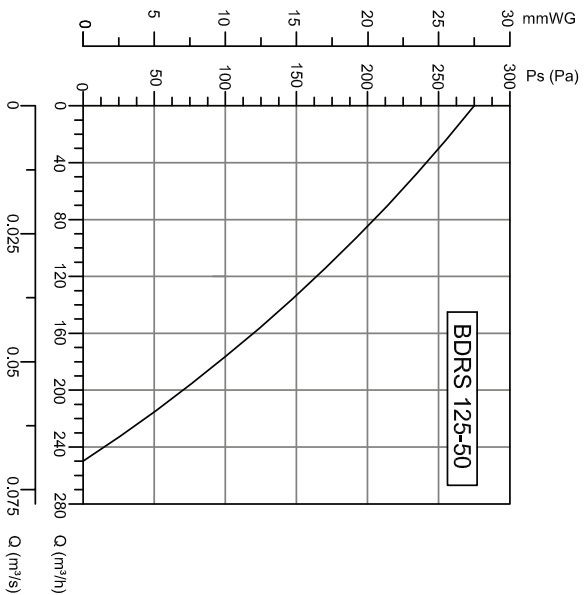

TYPE	VOLTAGE		FREQUENCY	POWER	CURRENT	CAPACITOR	SPEED	AIR FLOW	SOUND PRESSURE LEVEL	WEIGHT
	V	Hz								
BDRS 125-50	230	50	85	0,38	2,5	2285	250	65	2,1	
BDRS 120-60	230	50	90	0,4	2,5	2325	275	66	2,3	
BDRS 140-60	230	50	140	0,6	4	2215	485	70	2,9	
BDRS 160-60	230	50	205	0,8	5	2000	600	74	4	